

HENCO MULTILAYER PIPE

EN



HEATING



SANITARY



GAS



UNDERFLOOR HEATING



Your Connection to Perfection

HENCO Multilayer Pipe PE-Xc/Aluminium/PE-Xc

HENCO with all the advantages of plastic and metal

- ▶ Butt welded aluminium pipe
- ▶ 100% oxygen-tight and water vapour diffusion tight
- ▶ Low coefficient of linear expansion, similar to metal pipe
- ▶ Entirely corrosion-resistant, also resistant against chemicals and electrochemicals
- ▶ Sound-insulation similar to entirely plastic pipe
- ▶ Electron beam crosslinked inner and outer pipe
- ▶ High resistance to pressure and temperature
- ▶ Smooth surface, less loss of pressure
- ▶ Light as plastic piping
- ▶ Flexible, easy to bend even at low temperatures, retains shape after bending

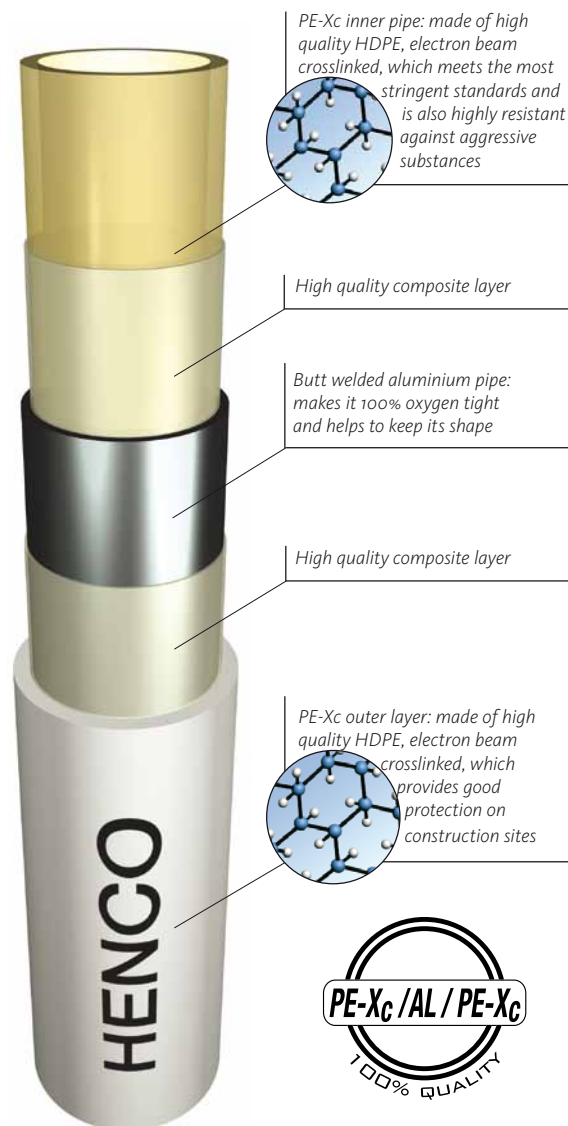
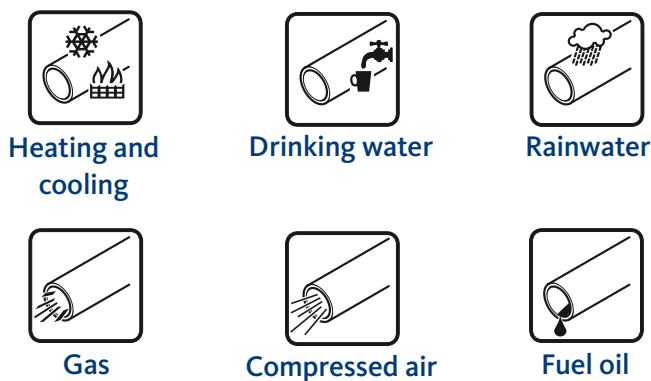

Technical Profile Henco Multilayer Pipe

Diameter (mm)	14	16	16 RiXc	18	18 RiXc	20	20 RiXc	26	26 RiXc	32	40	50	63
Inner diameter (mm)	10	12	12	14	14	16	16	20	20	26	33	42	54
Wall thickness (mm)	2	2	2	2	2	2	2	3	3	3	3,5	4,0	4,5
Thickness aluminium (mm)	0,4	0,4	0,2	0,4	0,2	0,4	0,28	0,5	0,28	0,7	0,7	0,9	1,2
Max. working temperature (°C)	95	95	95	95	95	95	95	95	95	95	95	95	95
Max. working pressure (bar)	10	10	10	10	10	10	10	10	10	10	10	10	10
Thermal conduction (W/mK)	0,43	0,43	0,43	0,43	0,43	0,43	0,43	0,43	0,43	0,43	0,43	0,43	0,43
Linear expansion (mm/mK)	0,025	0,025	0,025	0,025	0,025	0,025	0,025	0,025	0,025	0,025	0,025	0,025	0,025
Surface roughness of inner pipe (µ)	7	7	7	7	7	7	7	7	7	7	7	7	7
Oxygen diffusion (mg/l)	0	0	0	0	0	0	0	0	0	0	0	0	0
Min. bending radius manual / external spring (mm)	5xDu	5xDu	8xDu	5xDu	8xDu	5xDu	7xDu	5xDu	7xDu	*	*	*	*
Min. bending radius with internal bending spring (mm)	3xDu	3xDu	8xDu	3xDu	8xDu	3xDu	5xDu	3xDu	5xDu	*	*	*	*
Crosslinking / inner and outer pipe (%)	60	60	60	60	60	60	60	60	60	60	60	60	60
Weight (kg/m)	0,108	0,125	0,101	0,132	0,118	0,147	0,129	0,261	0,252	0,39	0,528	0,766	1,155
Water volume (l/m)	0,072	0,113	0,113	0,154	0,154	0,201	0,201	0,314	0,314	0,53	0,803	1,32	2,042
Per coil (m)	100 200	50 100 200	100 200	100 200	100 200	100	100	50	50	50	-	-	-
Straight lengths (m)	2-3-4-5	2-3-4-5	2-3-4-5	2-3-4-5	2-3-4-5	2-3-4-5	2-3-4-5	2-3-4-5	2-3-4-5	2-3-4-5	2-3-4-5	2-3-4-5	2-3-4-5

* only use elbows

Multilayer pipe and PVDF fittings: a corrosion free system

Henco press fittings in PVDF¹ (Ø14-63)

Leak before press!²

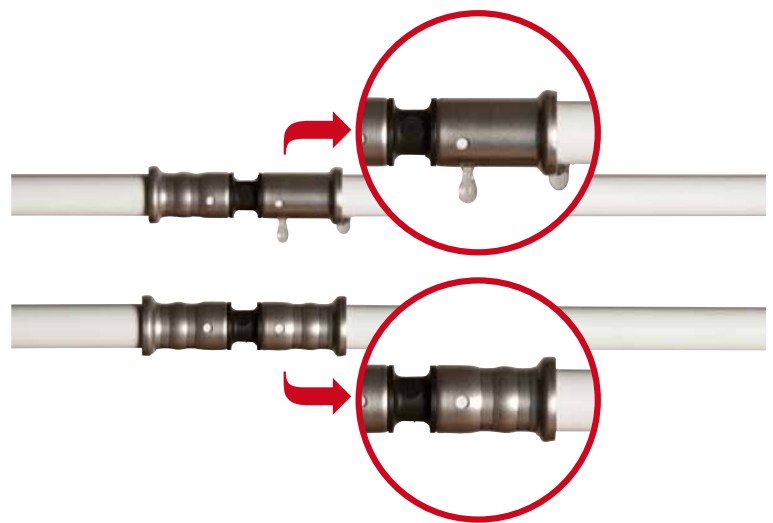
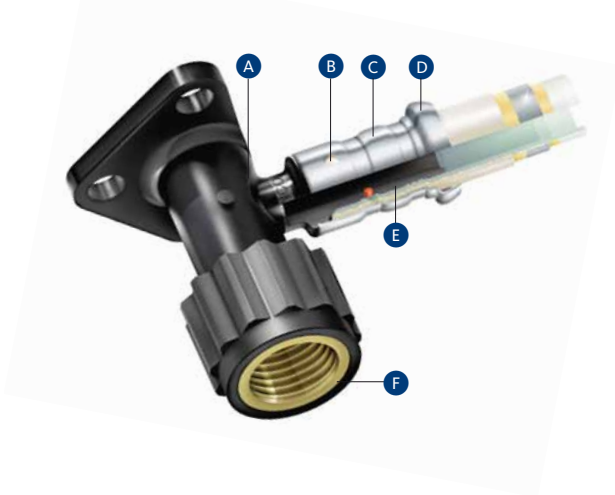

- A PVDF body
- B Viewing window to check the pipe is fully inserted
- C Stainless steel shoulder to locate into the jaws of the press tool
- D Pressure sleeve of stainless steel
- E EPDM O-ring
- F DZR brass: dezincification resistant

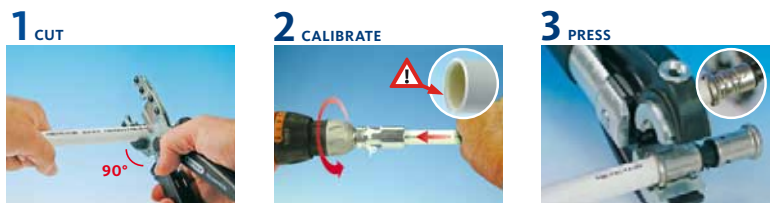

Henco Vision push fittings in PVDF¹ (Ø16-20-26)

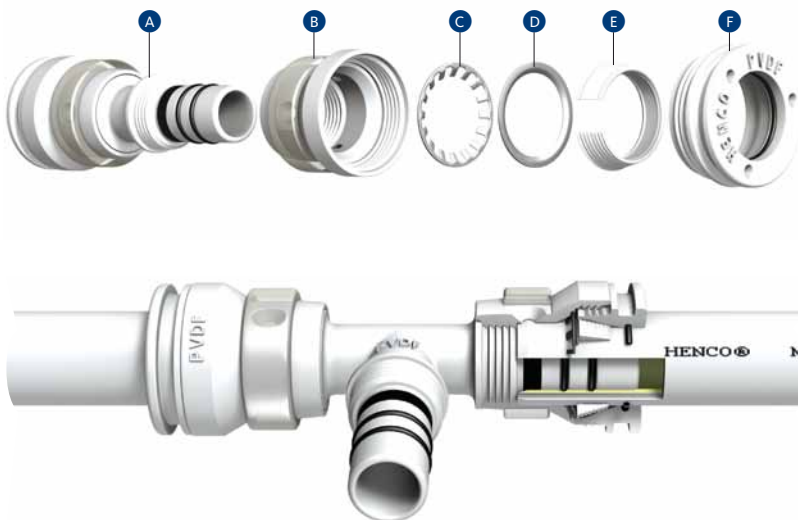

- A PVDF body with EPDM O-rings
- B PVDF sleeve with Vision window
- C Stainless steel grab ring
- D Stainless steel support ring
- E PVDF tapered split ring
- F PVDF end cap with EPDM O-ring and demounting slots

Quickly demountable

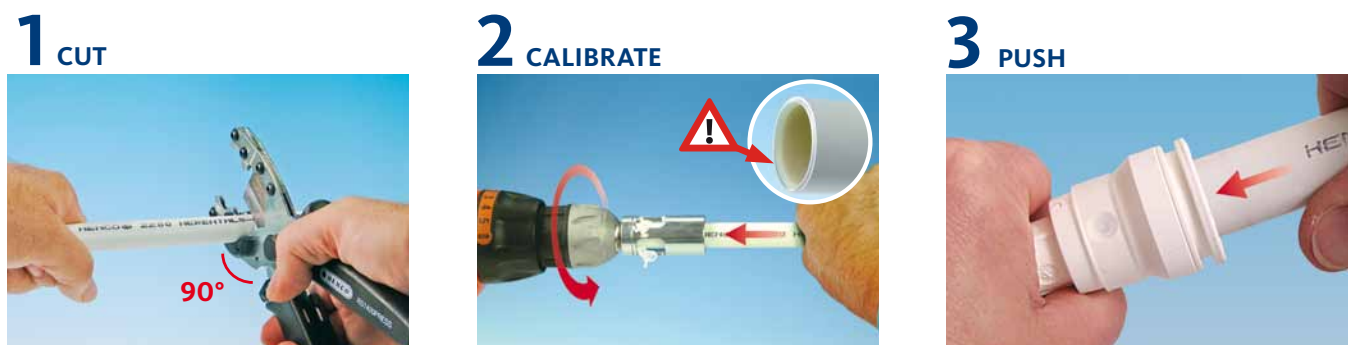

¹ High quality synthetic material (Polyvinylidene fluoride)
² Ø 14-26

Henco Vision manifolds in PVDF: a fully modular system

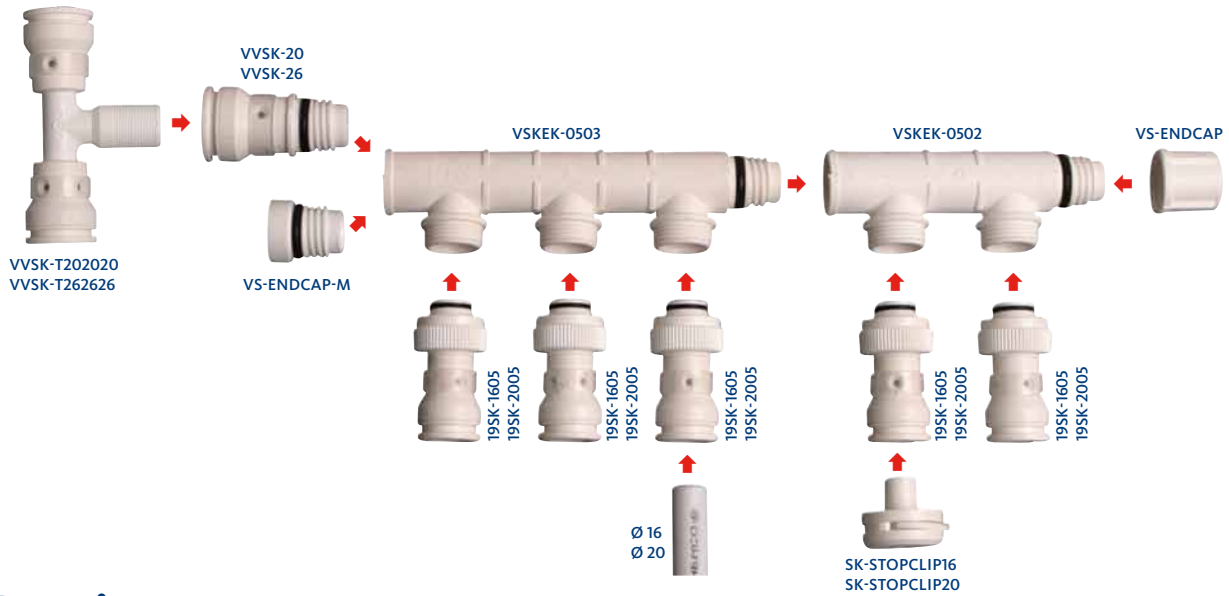

Practice



Henco Press



Henco Vision



Henco Vision manifolds



Henco Underfloor heating



Henco multilayer pipe



Henco multilayer pipe with conduit



Henco preinsulated multilayer pipe



Henco multilayer pipe with conduit for gas



Henco Combi

Certificats all over the world confirm the HENCO top quality



Henco 10 year system guarantee



Your Connection to Perfection

