

# HENCO VISION

ENG



RADIATOR



SANITARY



Your Connection to Perfection

## HENCO VISION: fast and reliable...for installers with Vision

### The bench-mark product among push-fit systems.

- ▶ Fast and easy to install
- ▶ Highest quality and durability
- ▶ For sanitary and heating installations

### PVDF, high quality synthetic material with a unique combination of properties.

The composition of the push-fit fitting shows that Henco Vision is the result of intensive product development. All the parts are made with the highest precision and of the best materials. The fitting is made of PVDF, a high quality synthetic material with a unique combination of properties:

- ▶ Resistant to high pressure and temperatures
- ▶ Excellent mechanical strength
- ▶ Flexibility of up to 10°
- ▶ Approved for use in drinking water systems

### Composition

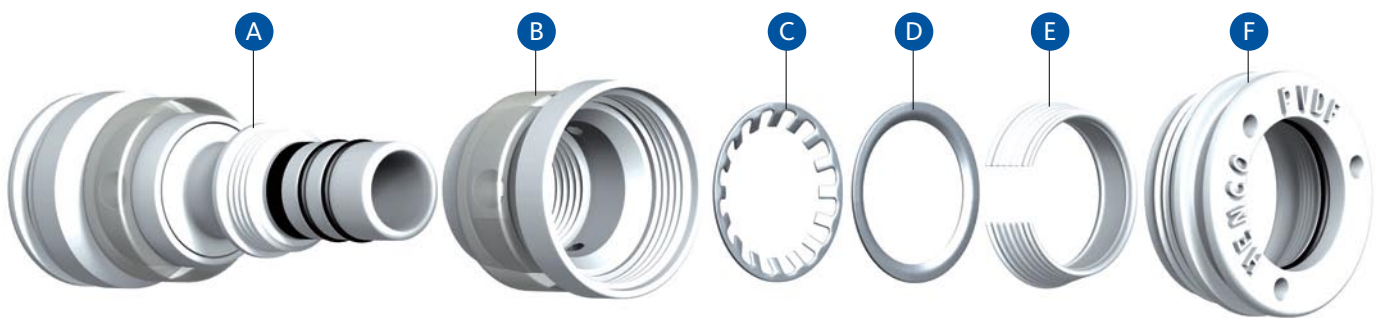

- A** PVDF body with EPDM O-rings
- B** PVDF sleeve with Vision window
- C** Stainless steel grab ring
- D** Stainless steel support ring
- E** PVDF tapered split ring
- F** PVDF end cap with EPDM O-ring and demounting slots

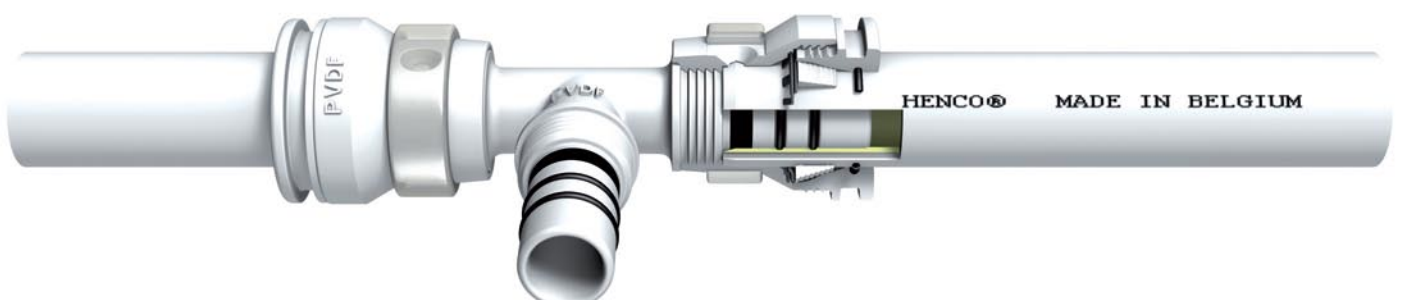

## Assembling Vision

With Vision there are three simple steps in making a reliable joint:

1. **CUT** - Ensure the pipe is cut at 90°. The Henco guillotine cutter has a handy cradle to support the pipe whilst cutting.
2. **CALIBRATE** - Calibrate the pipe with the Henco Kalispeed. Slide the calibrator right into the pipe, rotate clockwise until a continuous bevel is cut to both the inner and outer edges of the pipe. Important, removal all swarth.
3. **PUSH** - After removing the protection cap push the pipe all the way into the fitting. Use the Vision window to ensure the pipe is fully home.

**1** CUT



**2** CALIBRATE

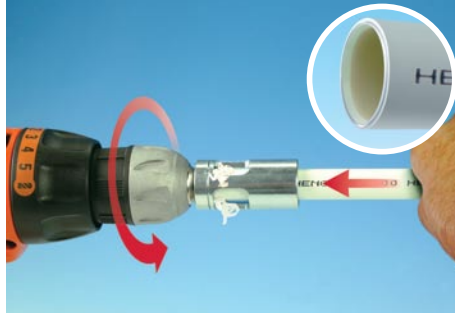

**3** PUSH



## Demounting Vision

Henco Vision can be demounted very quickly.

Even O-rings can easily be changed; for example when you remark a leak during pressure testing, probably caused by bad calibration.

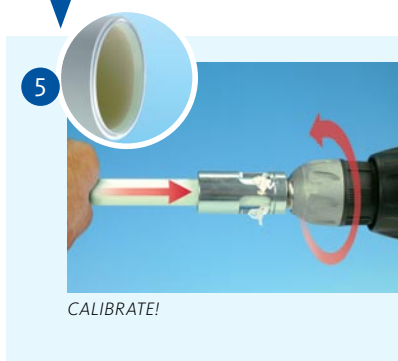
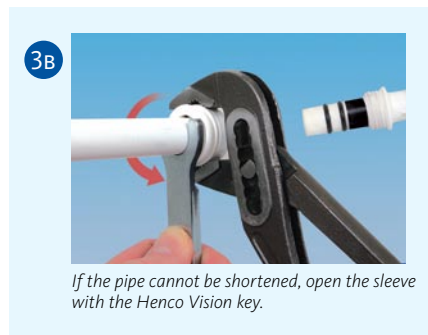
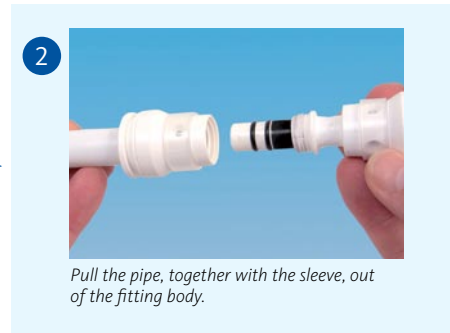

## ADVANTAGES



Henco Vision is supplied with a protection cap to avoid dirt getting into the fitting.



Vision – quickly demountable.



The outer O-ring and Vision window cover forms a seal to prevent the ingress of dirt, water, additives or concrete into the fitting.



Vision – easily reassembled.



Two internal O-rings form a seal on the inside of the pipe.



Vision – pleasing to the eye.



Vision has a unique support ring providing extra strength and stability to the grab ring. Safety guaranteed!



Vision – easily installed where space is restricted.

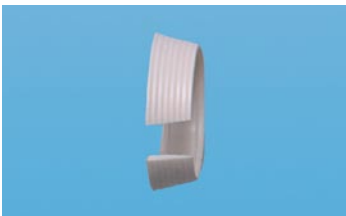

Vision's innovative design incorporates a unique tapered split ring. In addition to providing support to the stainless steel rings, this ground breaking design prevents expansion of the pipe within the fitting, eliminating pull-out failure.



Vision – fittings withstand up to a 10° flexion.



Vision – visibly better.



Vision is available in diameters of 16, 20 and 26mm.

In line with our history of innovation, and after years of ground-breaking research and intensive development, Henco are proud to introduce Vision – A further addition to Henco's comprehensive range.

This confidence is underlined by the 10 year Henco system guarantee.

