

HENCO ECOLINE

**PVDF
PRESS**

Advantages

- ▶ Energy saving
- ▶ Cost effective
- ▶ Easy installation
- ▶ Less space consumption
- ▶ Anti legionellosis



The saving circulation pipe

The Henco ECO-line is an energy saving solution for recirculation loops, which limits heat loss between supply and return pipe.

A separate pipe for the circulation water is no longer required.

Designed on the Henco Super Size concept, it also combines modularity and easy installation.

One concept for all dimensions from 40 up to 75 mm!

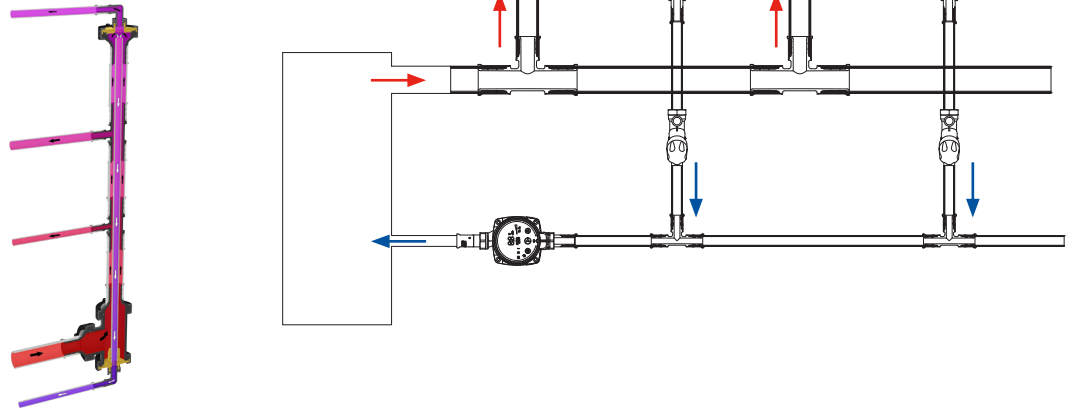

Necessary items to complete the ECOLINE installation



Henco 1L PEXc

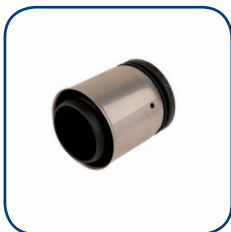

8HNA
Ø 40-50-63-75



19PK
Ø 16-20



19SK
Ø 16-20



19P
Ø 16-20



33P
Ø 16

* To complete the Ecoline installation you need to have a circulator and thermostatic balancing valve (not in Henco range)



WE CARE TO CONNECT

