

CU-ZONE-RF

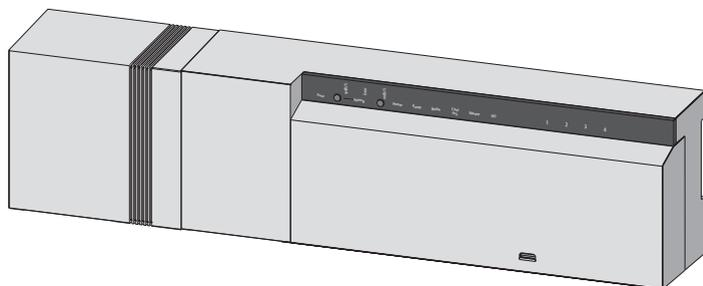
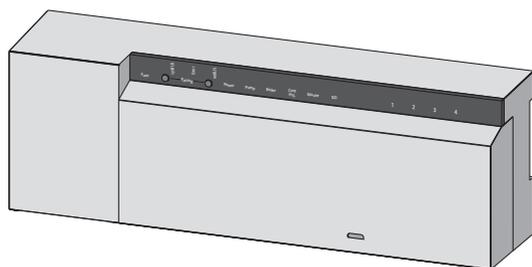

Contents

1 Safety	23
1.1 Used signal words and notes	23
1.2 Intended use	23
1.3 General safety notes	23
1.4 Personnel-related preconditions	24
1.5 Limitations for the operation	24
1.6 Conformity	24
2 Versions	25
2.1 Scope of supply	25
2.2 Indications and operating elements	25
2.3 Connections	26
2.4 Technical data	27
3 Installation	28
3.1 Assembly	28
3.2 Electric connection	28
3.2.1 External change-over signal	29
3.2.2 Pump/boiler 230 V	29
3.2.3 Optional humidity sensor	29
3.2.4 Pilot function for change-over heating/cooling	30
3.2.5 External timer	30
3.2.7 Use of a safety temperature limiter	31
3.2.8 Connection of Ethernet variants	31
4 Commissioning	32
4.1 First commissioning	32
4.2 Connecting (pairing) / separating base stations	32
4.2 Connecting (pairing) / separating base stations (continued)	33
4.3 Allocation of a room control unit to a heating zone (pairing)	33
4.4 Performing the radio test	33
4.5 System configuration	34
4.5.1 System configuration with microSD card	34
4.5.2 Configuration with room control unit Wireless Display	34
4.6 Resetting the factory settings	36
5 Protection functions and emergency operation	37
5.1 Protection functions	37
5.1.1 Pump protection function	37
5.1.2 Valve protection function	37
5.1.3 Antifreeze protection function	37
5.1.4 Dew point monitoring	37
5.1.5 Safety temperature limiter	37
5.2 Emergency operation	37
6 Troubleshooting and cleaning	38
6.1 Error indication and elimination of errors	38
6.2 Fuse change	39
6.3 Cleaning	39
7 Decommissioning	40
7.1 Decommissioning	40
7.2 Disposal	40

DEU

ENG

FRA

NDL

ITA

ESP

1 Safety

1.1 Used signal words and notes

The following symbols show you, that

- an action must be performed.
- ✓ a precondition must be met.



Warning

Electrical voltage! Danger to life!

The shown symbol warns against electrical voltage. Warning notes are highlighted with horizontal lines.

1.2 Intended use

The base stations CU-8ZONE-RF and CU-10ZONE-RF serve

- ✓ for the arrangement of a single room regulation system (readjustment) with a maximum of 12 zones (depending on the type used) for heating and cooling systems,
- ✓ for the connection of a maximum of 18 actuators and 12 room control units (depending on the type used), a pump, a CO signalling unit, a humidity sensor with potential-free contact as well as an external timer,
- ✓ for a fixed installation.

Every other use is considered as **not intended**; the manufacturer cannot be held liable for this.

Modifications and conversions are expressly forbidden and lead to dangers the manufacturer cannot be held liable for.

1.3 General safety notes



Warning

Electrical voltage! Danger to life!

The base station is live.

- Always disconnect from the mains network and secure against unintended activation before opening it.
 - Disconnect external voltages existing at the pump and the boiler contact and secure against unintended activation.
-

Emergency

- In case of emergency, disconnect the complete single room control system.



Retain this manual and provide it to future owners.

DEU

ENG

FRA

NDL

ITA

ESP

1.4 Personnel-related preconditions

Authorised specialists

The electrical installations must be performed according to the current VDE regulations as well as according to the regulations of your local electric power utility company. These instructions require special knowledge corresponding to an officially acknowledged **degree** in one of the following professions:

✓ **Electrical Equipment Installer or Electronics Engineer**

according to the profession designations officially announced in the Federal Republic of Germany, as well as according to comparable professions within the European Community Law.

1.5 Limitations for the operation

This unit is not intended to be used by people (including children) with restricted physical, sensory or mental skills or who lack experience or knowledge, except if they are supervised by a person responsible for their safety or have received instructions on how to use this unit.

Children must be monitored in order to ensure that they do not play with the device.

1.6 Conformity

This product is labelled with the CE Marking and thus is in compliance with the requirements from the guidelines:

- ✓ 2004/108/EG with amendments “Council Directive on the approximation of the laws of the Member States relating to Electromagnetic Compatibility”
- ✓ 2006/95/EG with amendments “Council for Coordination of the Regulations of EU Member Countries regarding the electrical equipment for use within certain voltage limits”
- ✓ “Radio and Telecommunications Terminal Equipment Act (FTEG) and Guideline 1999/5/EG (R&TTE)”

Increased protection requirements may exist for the overall installation, the compliance of which is the responsibility of the installer.

2 Versions

2.1 Scope of supply

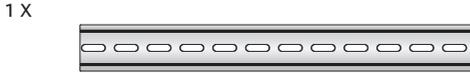
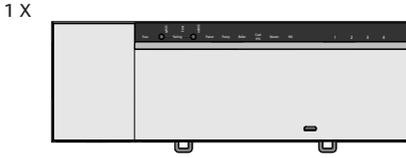

2.2 Indications and operating elements

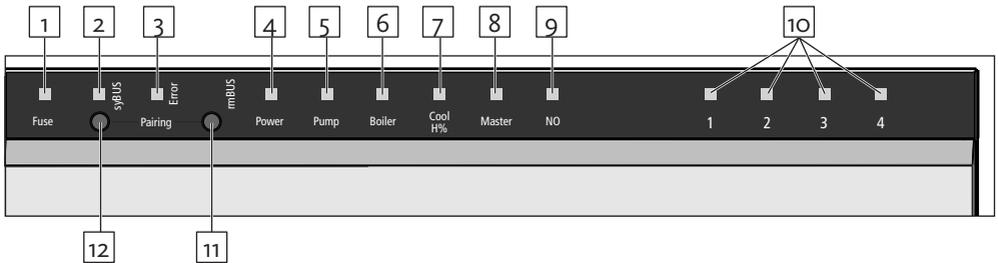

No.	Designation	LED	Function
1	Fuse	red	Lights up when fuse has blown
2	syBUS	yellow	Shows syBUS activity, flashes during writing access on microSD card
3	Error	red	Lighting up: Safety temperature limiter active
4	Power	green	Lighting up: Base station ready for operation.
5	Pump	green	Lighting up: Pump control active
6	Boiler	green	Lights up when boiler control is active if the boiler relay is used for boiler control.
7	Cool H%	blue	Lighting up: Cooling operation active. Flashing: Condensation detected.
8	Master	yellow	Lighting up: Base station is defined as master Flashing: Base station is defined as slave
9	NO	yellow	Lighting up: Installation is parameterised for NO actuators (normally open).
10	Heating zones 1 - x	green	Shows the respective activity of the heating/cooling zones.
11	rmBUS pushbutton	-	Push-button for the rmBUS functionality
12	syBUS pushbutton	-	Push-button for the syBUS functionality

DEU

ENG

FRA

NLD

ITA

ESP

2.3 Connections

230 V

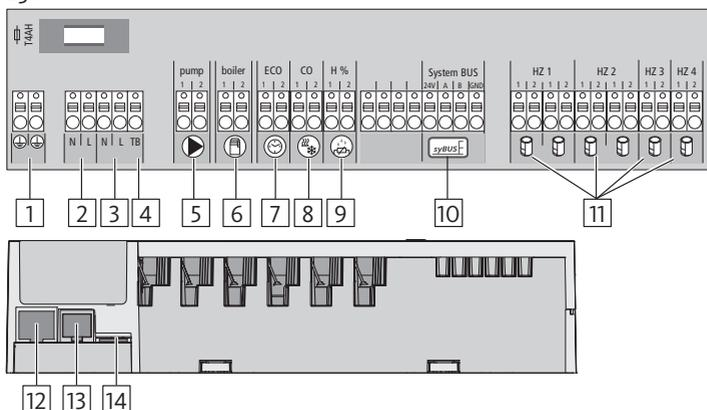

No.	Connections	Function
1	Protective conductor 1 and 2	Protective conductor connections
2	Temperature limiter	Connections for temperature limiter for the protection of sensitive surfaces, to be provided by the customer (optional)
3	Mains connection N/L	Connection for mains supply
4	Output 230 V	Optional assignment for a direct energy supply of the pump
5	Pump	Pump activation connection
6	Boiler	Boiler control connection, or output for CO pilot function
7	ECO	Potential-free input for the connection of an external timer
8	Change over	Potential-free input (according to SELV) for an external change-over signal
9	Dew point sensor	Potential-free input (according to SELV) for dew point sensor
10	syBUS	Connects several base stations in order to exchange global system parameters
11	Actuators	6 to 18 connections for thermal actuators
12	RJ45 connection	Ethernet interface for the Integration of the base station into the home network
13	RJ12 connection	Connection for active antenna
14	microSD card slot	Allows the introduction of firmware updates and individual system settings.

2.4 Technical data

	CU-8ZONE-RF	CU-12ZONE-RF
Ethernet	x	x
Number of heating zones	8	12
Number of actuators	4x2 + 4x1	6x2 + 6x1
Max. nominal load of all actuators	24 W	
Switching power per heating zone	max. 1A	
Operating voltage	230 V / $\pm 15\%$ / 50 Hz	
Mains connection	NYM connection terminals 3 x 1.5 mm ²	
Power consumption (without pump)	50 W	
Power consumption in idle operation/ with transformer	2,4 W	
Protection class	II	
Protection degree/overvoltage category	IP20 / III	
Fuse	5 x 20 mm, T ₄ AH	
Environment temperature.	0°C - 60°C	
Storage temperature	-25°C tot +70°C	
Humidity	5 - 80% niet condenserend	
Dimensions	290 x 52 x 75 mm	355 x 52 x 75 mm
Material	PC+ABS	
Controlling precision of the target value:	± 1 K	
Hunting	$\pm 0,2$ K	
Modulation	FSK	
Carrier frequency	868 MHz, bidirectional	
Coverage	25 m in buildings / 250 m in open air	
Radiated power	max. 10 mW	

DEU

ENG

FRA

NDL

ITA

ESP

3 Installation

3.1 Assembly

Warning  Electrical voltage! Danger to life!

All installation work must be performed under the absence of voltage.

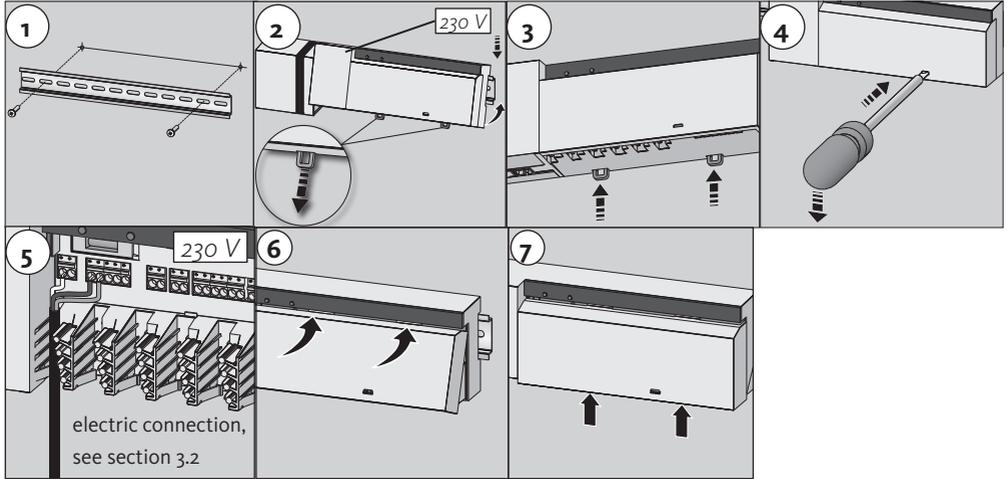

3.2 Electric connection

Warning  Electrical voltage! Danger to life!

All installation work must be performed under the absence of voltage.

The wiring of a single room control system depends on several factors and must be planned and carried through carefully by the installer.

The following cross-sections are applicable for the plug-in/clamping connections:

- ✓ solid wire: 0.5 – 1.5 mm²
- ✓ flexible wire: 1.0 – 1.5 mm²
- ✓ 8 - 9 mm insulation stripped off the wire
- ✓ The wires of the actuators can be used with factory-mounted end sleeves.

Note: Voltage can be supplied via one of the two N and L terminal pairs.

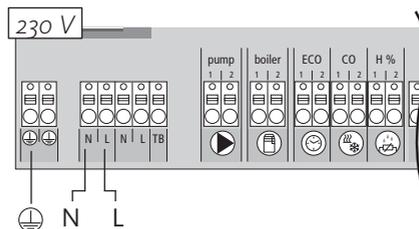

3.2.1 External change-over signal

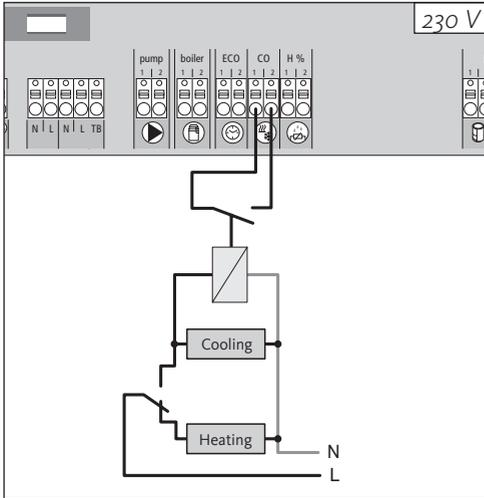

If an external change-over signal is used, the overall installation switches accordingly between heating and cooling.

3.2.2 Pump/boiler 230 V

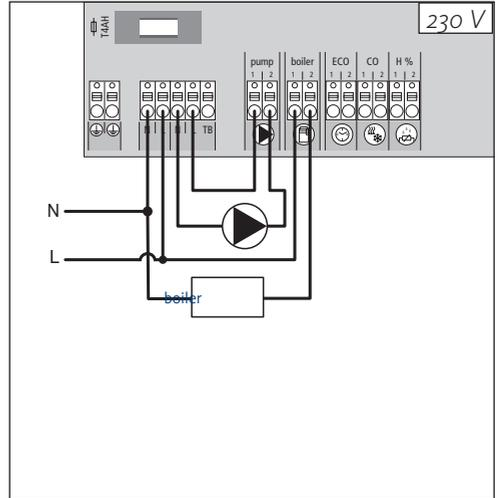

The boiler connection allows the control of a heat generator. Additionally, a pump can be controlled directly.

3.2.3 Optional humidity sensor

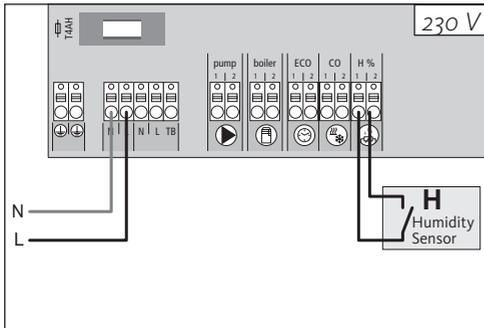

Humidity sensors (to be provided by the customer) serve for dewing protection in the cooling mode.

- DEU
- ENG
- FRA
- NDL
- ITA
- ESP

3.2.4 Pilot function for change-over heating/cooling

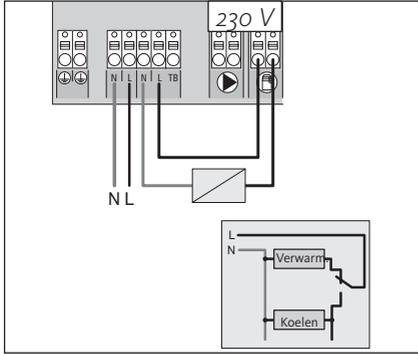

3.2.5 External timer

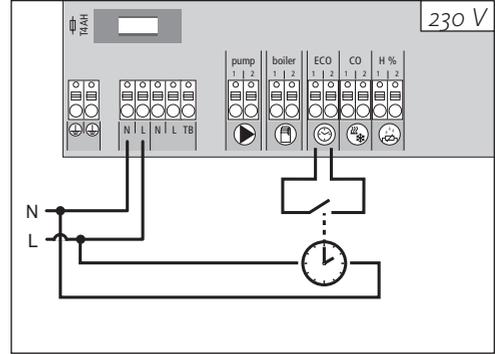

If no external change-over signal is available, the internal pilot function of the base station can be used for switching the overall installation between the operating modes Heating and Cooling. A relay used by the base station for switching over is used for this.

The base station is equipped with an ECO input for connecting an external timer, if the internal clock of the room control unit Radio Display shall not be used. When the input is activated by the timer, the heating zones are switched to night operation.

3.2.6 System BUS

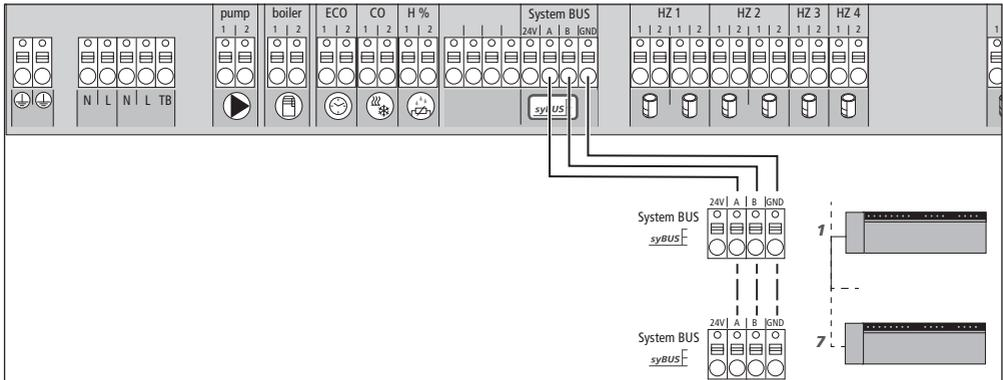

A maximum of seven base stations can be interconnected via the system BUS (syBUS) in order to exchange global system parameters. After completing the wiring, the base stations must be paired – see section 4.2 For a line diameter <6 mm, a strain relief must be provided by the customer.

Note! The base stations can also be connected via radio, see section 4.2. A mix of both variants is possible.

3.2.7 Use of a safety temperature limiter

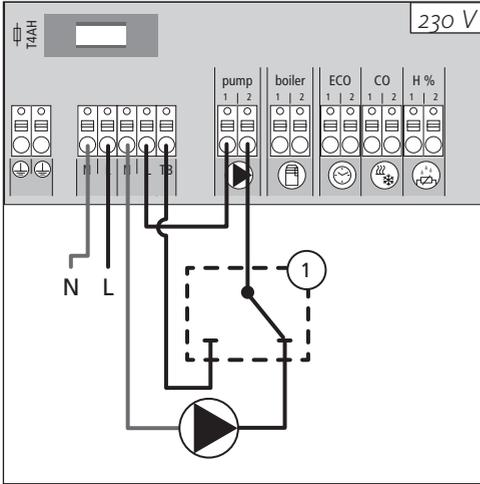

Connection of a customer-supplied safety temperature limiter (1). This device switches off the pump and sets the input to TL if too high flow temperatures for the floor heating are detected. If the TL input is switched, the base station shuts down all actuators automatically.

3.2.8 Connection of Ethernet variants

The base stations CU-8ZONE-RF and CU-10ZONE-RF are equipped with a RJ45 interface and an integrated web server for the control and the configuration of the system via PC/laptop and over the Internet.

- Integration of the base station into the network via network cable, or direct connection to PV/laptop

Set-up in the home network

- Open the router menu (see manual of the respective device) via the address bar in the web browser (Internet Explorer, Firefox, ...).
- Open an overview of all devices in the network.
- Compare to the MAC address (see type sign) in order to find out the IP address allocated to the base station.
- Note the IP address of the base station and enter it into the address bar of the web browser in order to open the web interface.

Direct connection to PC/laptop:

- Open the network settings in the PC/laptop and assign the IP address 192.168.100.1 as well as the subnet mask 255.255.0.0 manually to the PC.
- Access to the web interface can be gained by entering the IP address 192.168.100.100 in the address bar of your web browser.

DEU

ENG

FRA

NLD

ITA

ESP

4 Commissioning

4.1 First commissioning

The base station is in installation mode during the first 30 minutes after switching on the mains voltage. The target and actual temperatures are compared in this mode, all other functions are deactivated. If the actual temperature is below the target temperature, the output allocated to the respective room control unit is activated at the base station. This allows signalling at the base station without delay, enabling the control of the allocation between the room control unit and the output of the base station.

- Switch on the mains voltage.
- ✓ The base station initialises the installation mode for 30 minutes.
- ✓ If the base station is parameterised for NC actuators, all heating zones are activated for 10 minutes in order to unlock the first-open function of the NC actuators.
- ✓ The power LED (operation display) lights up continuously.

4.2 Connecting (pairing) / separating base stations

If several base stations are used in one heating system, a maximum of seven units can be coupled (paired) for the exchange of global system parameters via radio or system bus (syBUS). The radio range of the base station must be observed for the radio connection. If the radio range is insufficient, pairing must be performed with the syBUS. Communication is done according to the master/slave principle. Requirements and status messages are exchanged between the units. The master unit centrally controls the directly connected functions/components:

- CO input/output
(if the pilot function is activated)
- Boiler output
- Pump output

Note: The base station the components are connected to must be configured as master. Further base stations can only be paired with the master.

The pairing of base stations is done as follows:

- Press the syBUS button of the base station to be configured as master for three seconds in order to start the pairing mode.
- ✓ The LED “syBUS” flashes.
- ✓ For three minutes, the pairing mode is ready to receive the pairing signal of another room control unit.
- Press the syBUS button of the base station to be configured as slave two times consecutively for one second, in order pair it with the master.
- ✓ The pairing mode ends automatically after the process has finished.
- ✓ The LED “Master” **lights** up permanently at the master base station.
- ✓ The LED “Master” **flashes** if the base station has been configured as slave.
- Repeat the process for pairing another base station.

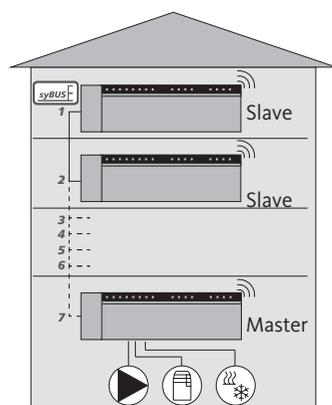

4.2 Connecting (pairing) / separating base stations (continued)

The separation of paired base stations can be performed as follows:

- Press the syBUS button of the base station to be separated for three seconds in order to start the pairing mode.
- ✓ The LED “syBUS” flashes.
- Press the syBUS pushbutton again for a duration of 10 seconds.
- ✓ The base station restarts and the LED “Master” goes out.

4.3 Allocation of a room control unit to a heating zone (pairing)

- Press the rmBUS button of the base station for three seconds in order to start the pairing mode.
- ✓ The LED “Heating zone1” flashes.
- Select the desired heating zone by pressing shortly again.
- ✓ For three minutes, the selected heating zone is ready to receive the pairing signal of a room control unit.
- Activate the pairing function at the room control unit (see Room Control Unit Manual).
- ✓ The pairing mode is left after establishing a successful allocation.
- ✓ The LED of the heating zone previously selected will light up for 1 minute.
- Repeat the process for allocating more room control units.

Tip One Room Control Unit can be allocated to various heating zones.
The allocation of several room control units to one zone is impossible.

4.4 Performing the radio test

The radio test allows to verify the communication between the base station and the room control unit. The radio test must always be carried through at the planned installation location of the room control unit.

- ✓ The base station must not be in pairing mode for this.
- Start the radio test at the room control unit (see Room Control Unit Manual).
- ✓ The heating zone allocated to the room control unit is activated for one minute, thus it is switched off or on depending on the status of operation.
- ✓ If there is no activation, the reception conditions are unfavourable. Proceed as follows:
 - Taking into account the installation conditions of the room control unit, change the installation position until you have a reception signal, or
 - Use the optional accessories “Active antenna” or “Repeater” in order to amplify the radio signal. You can find information on the installation in the respective manual.

4.5 System configuration

The configuration of the base station is done optionally via the microSD, the software interface of the Ethernet variant or the Service level of the room control unit Bus Display.

4.5.1 System configuration with microSD card

Individual settings can be made via the EZR Manager SD Card under www.ezr-home.de and transferred to the base station via the microSD card. As of software version 01.70, the base station accepts microSD cards >2 GB in the formats FAT16 or FAT32.

- Open www.ezr-home.de in the web browser of your PC, select EZR Manager SD Card and follow the instructions on-line.
- Insert the microSD card with the updated data into the base station.
- ✓ The transfer process will start automatically and copy the updated data into the base station.
- ✓ The LED “syBUS” flashes during the transfer process.
- ✓ After a successful data transmission, the LED “syBUS” goes out.

4.5.2 Configuration with room control unit Wireless Display

The **Service level** of the base station Wireless Display is protected with a PIN code and may only be used by authorized specialists.

Attention! Faulty configuration leads to errors and damage to installations.

- Press the rotary control.
- Select the menu “Service Level” and activate by pressing.
- Enter the 4-digit PIN (standard: 1234) by rotating and pressing.
- Select parameters (PAR) by pressing again and enter the number code of the desired parameter (see following table).
- Change parameters as required and confirm by pressing.

No.	Parameters	Description	Unit
010	Used heating system	Adjustable per heating zone: Floor heating (FBH) standard / FBH low energy / radiator / convector passive / convector active	FBH St.=0 FBH NE=1 RAD=2 KON pas.=3 KON act.=4
020	Heating/cooling block	Blocking the switching outputs depending on the activated operating mode (heating/cooling)	normal=0 Heating block=1 Cooling block=2
030	Operation lock (child safety lock)	Unlocking the operating lock with password protection	Deactivated=0 Activated=1
031	Operating lock password	Determine PIN if parameter 30 is set to active	0000..9999

4.5.2 Configuration with room control unit Wireless Display (continued)

No.	Parameters	Description	Unit
040	External sensor connected to the RBG	Logging on an additional sensor for the registration of the floor temperature (FBH), the room temperature or the dew point	no sensor=0 Dew point sen.=1 Temp FBH=2 Temp room=3
060	Correction of actual value registration	Registration of the actual temperature with a correction factor	-2.0...+2.0 K in 0.1 increments
110	Control direction switching outputs	Switchover of NC and NO actuators (only globally)	NC=0 / NO=1
115	Use as setback input	Change-over between use of the ECO input for setback or holiday function of the room control unit. The holiday function cannot be activated any longer via the room control unit if this parameter has been set to 1.	ECO=0 Holiday=1
120	Unit of temperature display	Toggle function of the display between degree Celsius and degree Fahrenheit	°C=0 °F=1
Pump configuration			
130	Pump output	Use the control of a local recirculation pump (in the heating circuit distributor) or a global recirculation pump (heating installation).	local=0 global=1
131	Pump type	Selection of the used pump: Conventional Pump (KP) / High efficiency Pump (HP)	CP=0 HP=1
132	Pump line-up time	Time elapsing from the moment of the command from a switching output until the pump is actually switched on.	[min]
133	Pump follow-up time	Time elapsing from the moment of switching off the switching outputs until the pump is actually switched off.	[min]
134	Control direction switching output	The control direction can be inverted if the pump relay is used as control output	normal=0 inverted=1
135	Minimum running time	The minimum running time indicates how long the HP must run until it may be switched off again.	[min]
136	Minimum standstill time	High efficiency pump: The pump may only be switched off if a minimum standstill time can be ensured.	[min]
Configuration of change-over functionality / boiler relay			
140	Function of relay boiler / CO output	Selection whether the switching output shall serve for controlling a pump relay, or as CO pilot	Boiler=0 CO pilot=1
141	Line-up time	Boiler relay line-up time for conventional pump	[min]
142	Follow-up time	Boiler relay follow-up time for conventional pump	[min]
143	Control direction switching outputs	The relay function can be inverted if used as a control output.	normal=0 inverted=1
160	Antifreeze protection	Activation of control outputs for $T_{\text{actual}} < x \text{ } ^\circ\text{C}$	Deactivated=0 Activated=1
161	Antifreeze temperature	Antifreeze function limit value	[°C]

DEU

ENG

FRA

NDL

ITA

ESP

4.5.2 Configuration with room control unit Wireless Display (continued)

No.	Parameters	Description	Unit
170	Smart Start	Learning-in of the temperature behaviour of the individual heating zones	Deactivated=0 Activated=1
Emergency operation			
180	Duration until activation	Duration until the activation of the emergency operation routine	[min]
181	PWM cycle duration in emergency operation	Duration of a PWM cycle in emergency operation	[min]
182	Cycle duration PWM heating	Control duration in heating operation	[%]
183	Cycle duration PWM cooling	Control duration in cooling operation	[%]
Valve protection function			
190	Duration until activation	Starting time after last activation	[d]
191	Valve activation duration	Valve activation duration (0= function deactivated)	[min]
Pump protection function			
200	Duration until activation	Starting time after last activation	[d]
201	Activation duration	Activation duration (0 = function deactivated)	[min]
210	First open function (FO)	Activation of all switching outputs at power-up	[min] Off=0
220	Automatic switching between summer and winter time	If the conversion is activated, time adaptation is performed automatically according to CET guidelines	Deactivated=0 Activated=1
230	Setback difference temperature	In case of activation of the setback via the external input	[K]

4.6 Resetting the factory settings

Attention! All user settings will be lost.

- If present, remove the microSD Card from the base station and delete the parameter file “params_usr.bin” at the PC.
- Press the rmBUS button of the base station Radio for three seconds in order to start the pairing mode.
- ✓ The LED “Heating zone1” flashes.
- Press the rmBUS pushbutton again for a duration of 10 seconds.
- ✓ All heating zone LEDs flash simultaneously; after another 5 seconds of pressing the pushbutton they light up simultaneously, and go out after that.
- ✓ Now the base station is reset to factory settings and behaves as it did during the first commissioning (see section 4).

Note! Previously allocated room control units must be paired newly, see section 4.3.

5 Protection functions and emergency operation

5.1 Protection functions

The base station is equipped with many protection functions for avoiding damage to the overall system.

5.1.1 Pump protection function

In order to avoid damage by longer standstill times, the pump is activated within pre-defined periods. The LED “pump” lights up during these periods.

5.1.2 Valve protection function

During periods without valve activation (e. g. outside the heating period) all heating zones with logged-in room control unit are activated in a cyclic way in order to avoid clogging of the valves.

5.1.3 Antifreeze protection function

Independent from the operating mode, every switching output is equipped with an antifreeze function. As soon as a previously set antifreeze temperature (5...10°C) is fallen short of, the valves of the allocated heating zone are activated until this temperature is reached. The antifreeze temperature can be set via the microSD card, via the software surface of the Ethernet variant or via the service level of the RBG display (parameter 161).

5.1.4 Dew point monitoring

If the installation is equipped with a dew point sensor (provided by the customer), the valves of all heating zones are closed if dewing is detected in order to avoid damages due to humidity. The dew point sensor input is only used during cooling operation.

5.1.5 Safety temperature limiter

If an optional safety temperature limiter is used, all valves are closed when a critical temperature is exceeded in order to avoid damage to sensitive floor coverings.

5.2 Emergency operation

If the base station is unable to establish a radio connection to the room control unit allocated to the heating zone after a set time has elapsed, emergency operation is activated automatically. In emergency operation, the switching outputs at the base station are activated with a modified PWM cycle duration (parameter 181) independent from the heating system in order to avoid complete cooling of the rooms (in heating operation) or dewing (in cooling operation).

DEU

ENG

FRA

NDL

ITA

ESP

6 Troubleshooting and cleaning

6.1 Error indication and elimination of errors

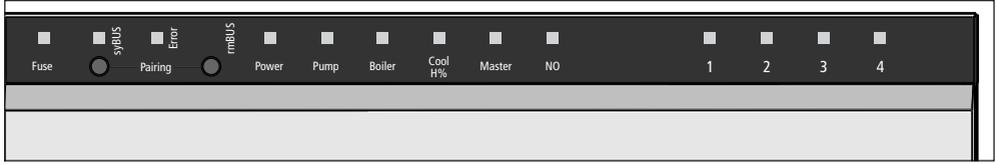

Signalling of the LEDs	Meaning	Elimination
<p>Fuse</p> <p>Duration in seconds</p> <p>Fuse</p>	Fuse defective	➤ Change the fuse (see section 6.2)
<p>Error / Pump</p> <p>Duration in seconds</p> <p>Pump Error</p>	Safety temperature limiter active, valves are closed	✓ The normal control operation is activated automatically after falling short of the critical temperature
<p>„Cool H%“ (only cooling operation)</p> <p>Duration in seconds</p> <p>Cool</p>	Dewing detected, valves are closed	✓ The normal control operation is activated automatically if no condensation is sensed any more.
<p>Heating zone</p> <p>Duration in seconds</p> <p>HZ off</p> <p>HZ on</p>	Radio connection to the room control unit faulty	➤ Change the position of the room control unit or use a repeater or an active antenna.
<p>Heating zone</p> <p>Duration in seconds</p> <p>HZ off</p> <p>HZ on</p>	Low battery capacity of the room control unit	➤ Change the batteries in the room control unit
<p>Heating zone</p> <p>Duration in seconds</p> <p>HZ</p>	Emergency operation active	<ul style="list-style-type: none"> ➤ Change the batteries in the room control unit ➤ Perform a radio test ➤ If necessary, reposition the room control unit. ➤ Replace a defective room control unit

LED on
 LED off

DEU
 ENG
 FRA
 NDL
 ITA
 ESP

6.2 Fuse change

 **Warning** Electrical voltage! Danger to life!

The base station is live.

- Always disconnect from the mains network and secure against unintended activation before opening the base station.

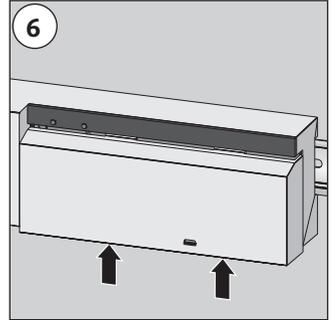
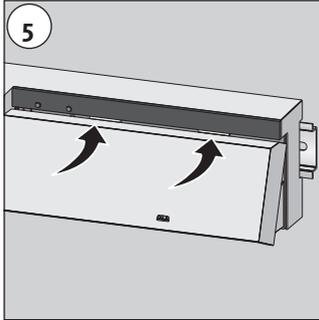
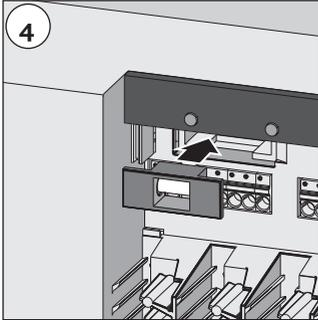
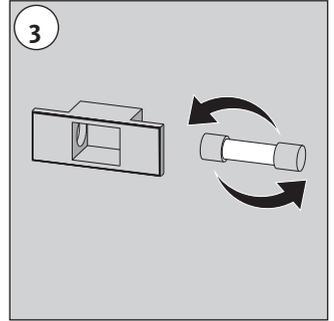
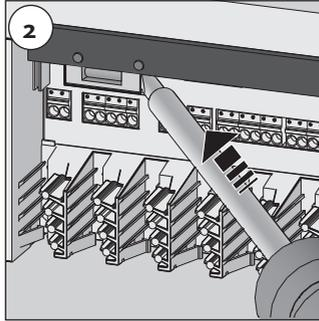
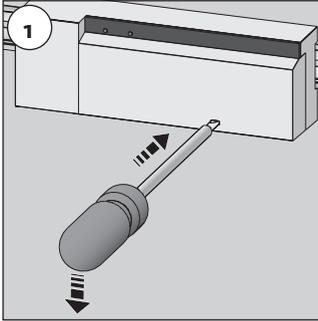

6.3 Cleaning

Only use a dry and solvent-free, soft cloth for cleaning.

DEU

ENG

FRA

NDL

ITA

ESP

7 Decommissioning

7.1 Decommissioning



Warning

Electrical voltage! Danger to life!

The base station is live.

- Always disconnect from the mains network and secure against unintended activation before opening it.
- Disconnect external voltages existing at the pump and the boiler contact and secure against unintended activation.

- Pull the mains plug and disconnect the entire installation.
- Remove the wiring to all externally connected components as e. g. pump, boiler and actuators.
- Uninstall the device and dispose of properly.

7.2 Disposal



The base stations must not be disposed of with domestic waste. The operator has the duty to hand the devices to appropriate collection points. The separate collection and orderly disposal of all materials will help to conserve natural resources and ensure a recycling in a manner that protects human health and the environment. If you need information about collection points for your devices, please contact your local municipality or your local waste disposal services.